

GARAGE DOOR CARE AND LUBE SCHEDULE

Whilst your garage door has been fully lubricated on installation there is a need for periodic lubrication. Lube points are listed (Fig. 1). Our experience has shown that a dry White Lithium grease lasts the longest. In coastal positions springs should be greased with solid grease such as white grease every six months.

For full service and maintenance please contact your garage door company once a year (charges apply).

The auto operator should be tested as often as it is listed in the manufacturers operating manual.

UP-KEEP - METAL DOORS

Occasional hose down is all that is required (more often in coastal, corrosive positions). The exterior of the door can be waxed with a quality automotive wax. It is important to keep the door and its tracks as free from sand and grit as possible.

UP-KEEP - WOODEN DOORS

Same as metal doors occasional hose down in the cool of the day is mostly required (more often in coastal, corrosive positions). Sponging, polishing or scrubbing is not recommended as most external timber finishes are soft and can be easily scratched. Re-coating becomes necessary when the sealer appears dull. Refer to the sealing and maintenance schedule for full instruction. A refresher coat every two to three years is strongly recommended to keep the timber protected and door looking like new.

Your garage door is guaranteed for 12 months against faulty materials, workmanship and installation. However, please note:

THAT REGULAR PREVENTATIVE MAINTENANCE IS THE RESPONSIBILITY OF THE GARAGE DOOR OWNER AND NOT COVERED BY THE WARRANTY.

LUBRICATION POINTS

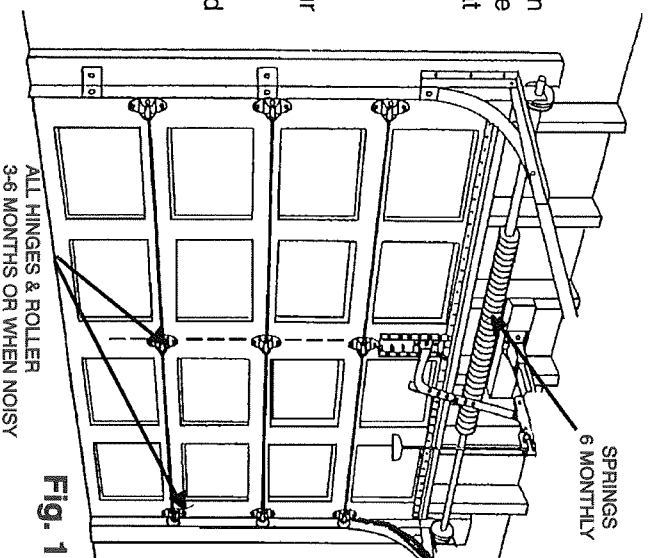

EMERGENCY DOOR OPERATION

In case of a power failure, your garage door operator has been fitted with an emergency release. This is located on the trolley under the main pole and has a release cord attached to it.

TO RELEASE THE DOOR (Fig. 2)

Pull the release cord in a downward direction. Use the handles provided on the back of the door to lift the door up or pull the door down.

DO NOT USE THE CORD TO PULL THE DOOR OPEN OR SHUT

This can break the lever as it is not designed as a towing point.

DO NOT PLACE FINGERS BETWEEN PANELS WHEN OPERATING THE DOOR AS IT MAY RESULT IN INJURY

TO RE-ENGAGE THE DOOR

Once the power has returned, simply push the lever upwards and move the door manually to allow the torpedo to engage inside the trolley.

AUTO-OPERATOR MAINTENANCE PROGRAM

Sensitivity should be checked as often as it is advertised in the Users Manual.

Check and adjust the chain tension and adjust the door travel limit and check all the fixtures for loose bolts and screws every six months or as per Users Manual.

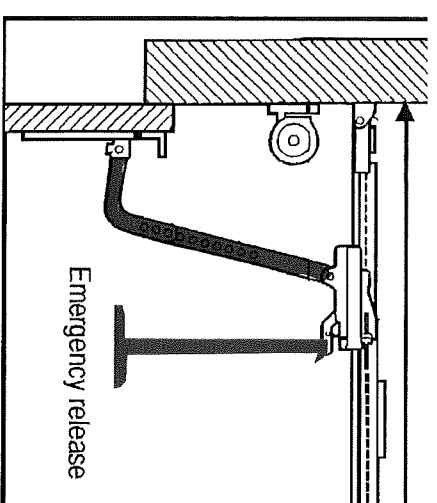

SERVICE CALLS DUE TO LACK OF LUBRICATION OR AUTO SENSITIVITY WILL BE INVOICED